

Werner Almesberger	
File: anelok.sch	
Sheet: /	
Title: Anelok Password Safe	
Size: A4	Date: 1 jun 2014
KiCad E.D.A.	Rev: 1/6

# Power + USB

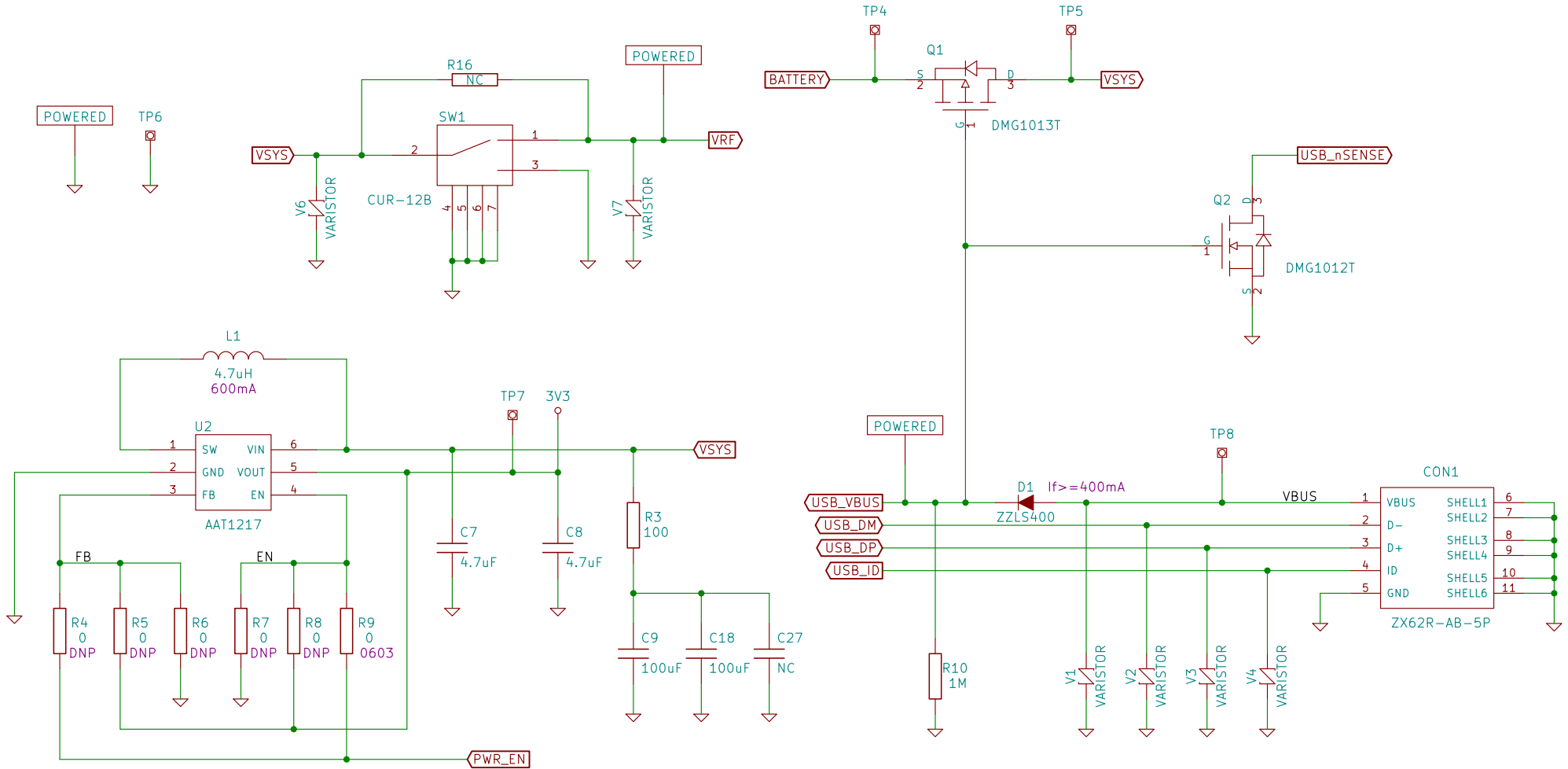

U2	R4	R5	R6	R7	R8	R9	C7	C8
AAT1217-3.3	-	-	-	-	-	OR	4.7uF	4.7uF
AAT1217-1.2	-	1.02M	604k	-	-	OR	4.7uF	4.7uF
TLV61220	OR	-	-	180k	1M	-	10uF	10uF

(FB and EN are swapped on TLV61220)

<b>Werner Almesberger</b>	
File: power.sch	
Sheet: /Power+USB/	
Title: Anelok Password Safe	
Size: A4	Date: 3 jun 2014
KiCad E.D.A.	Rev: 2/6

# Display

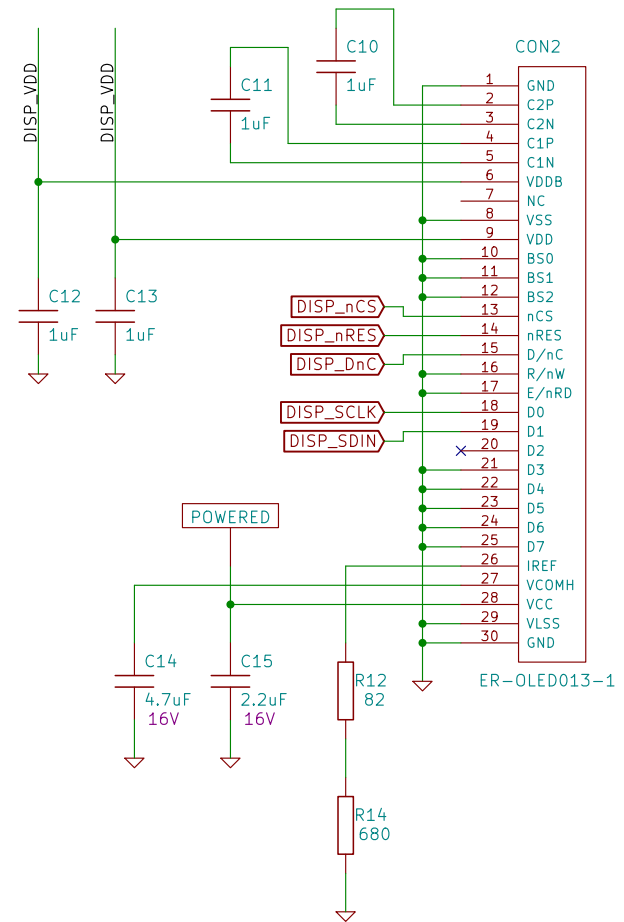
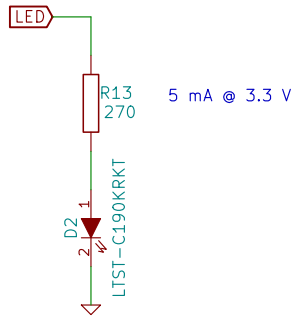
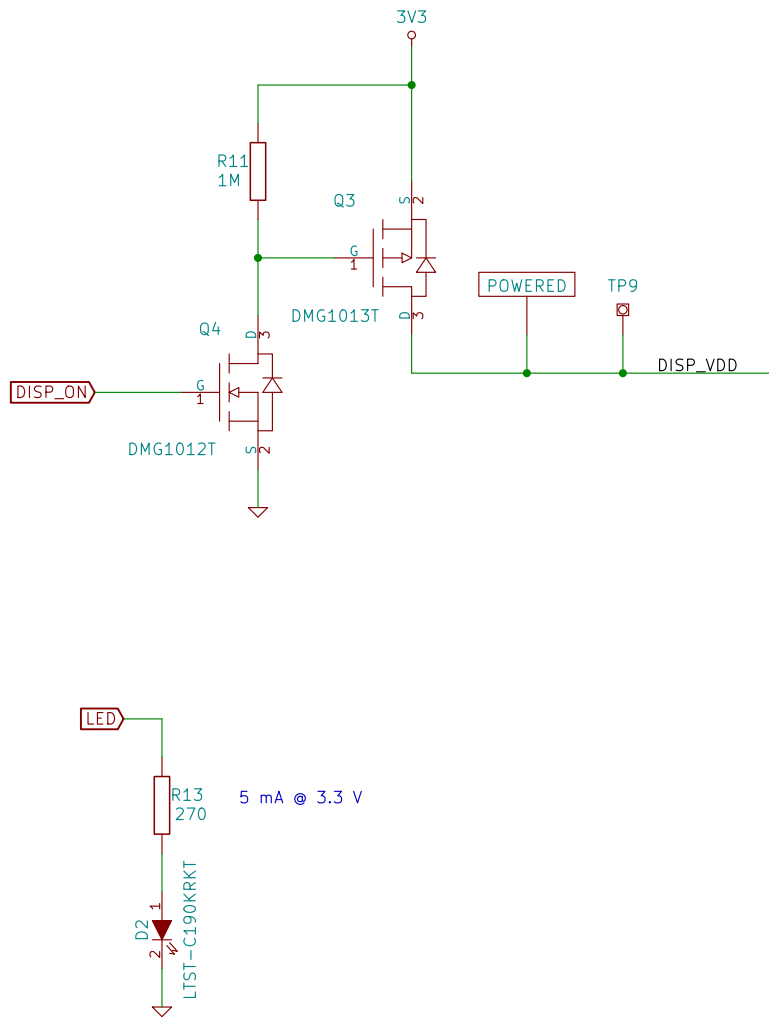

Werner Almesberger	
File: disp.sch	
Sheet: /Display/	
Title: Anelok Password Safe	
Size: A4	Date: 31 may 2014
KiCad E.D.A.	Rev: Id: 3/6

# RF

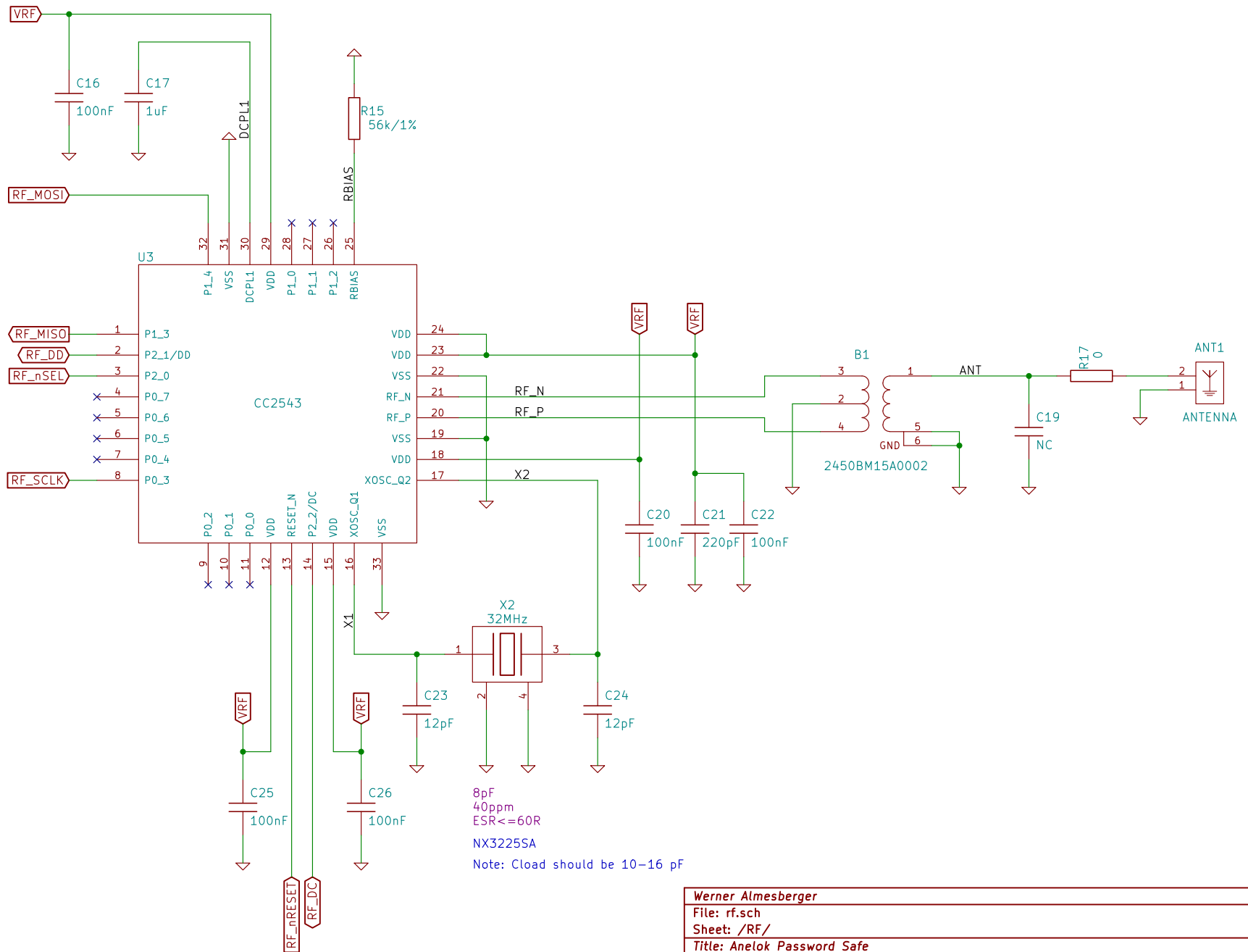

8pF  
40ppm  
ESR<=60R  
NX3225SA  
Note: Load should be 10-16 pF

Werner Almesberger	
File: rf.sch	
Sheet: /RF/	
Title: Anelok Password Safe	
Size: A4	Date: 1 jun 2014
KiCad E.D.A.	Rev: Id: 4/6

# Memory card

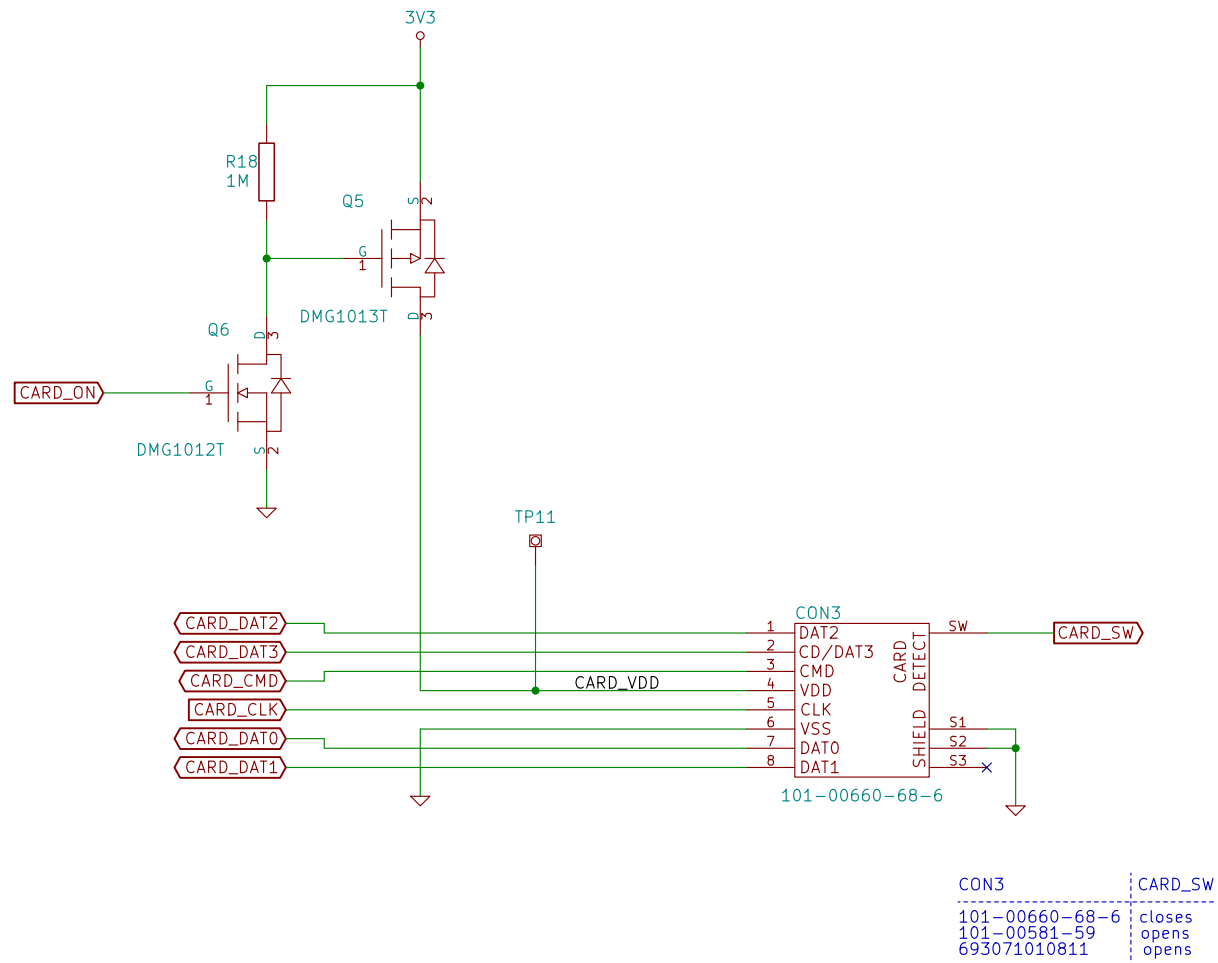

Werner Almesberger	
File: memcard.sch	
Sheet: /Memcard/	
Title: Anelok Password Safe	
Size: A4	Date: 31 may 2014
KiCad E.D.A.	Rev: Id: 5/6

# Sub-board

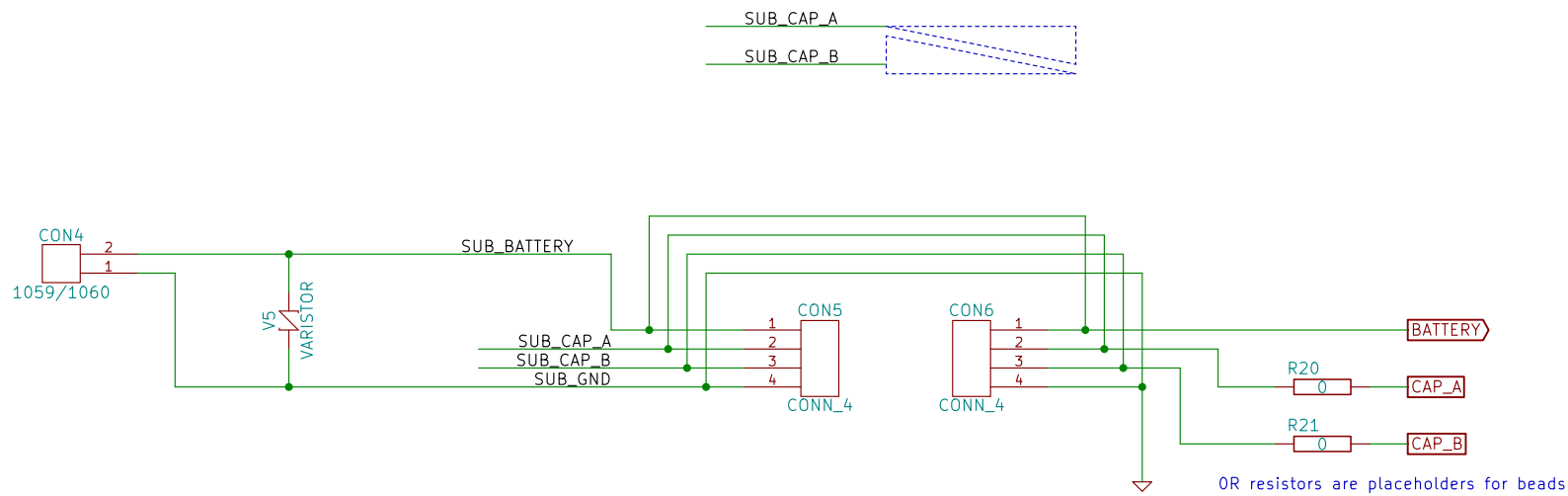

File: sub.sch	
Sheet: /Sub-board/	
Title:	
Size: A4	Date: 1 jun 2014
KiCad E.D.A.	Rev: 6/6