

APPROVAL SHEET

Qi Hardware Inc.

Item : SO7050 Crystal Oscillator

Spec. no : SO7050-050000-O3A-BBE-QA

Freq : 50.000 MHz

Customer Approved	Checked By	Issued By
		

友桂電子股份有限公司 YOKETAN CORPORATION

E-mail: yoketec@ms14.hinet.net [http:// www.yoketant.com.tw](http://www.yoketant.com.tw)

Taichung Factory : 28-2 , NAN 2ND Rd , T.E.P.Z , Taichung , Taiwan (42760)

Tel: 886-4-25333353 Fax: 886-4-25338675

Taipei Office : 9F-3 , No.107 , Sec. 1,Zhongshan Rd., Xinzhuang City , Taipei , Taiwan (24250)

Tel: 886-2-85227548 Fax: 886-2-85227546

China Factory : Block C-3F, Da Zhou Ind. Estate , North Zhan Gang Rd, Zhaoqing City, Guangdong Province , P.R.C. (526020)

Tel: 86-758-6152666 Fax: 86-758-6152699

Shenzhen Office : North Road, Luohu District, Shenzhen Honggang Building, Honggang 2106 , P.R.C. (518008)

Tel: 86-755-25936978 Fax: 86-755-25907970

Wuxi Office : Block C-3F, Da Zhou Ind. Estate, North Zhan Gang Rd, Zhaoqing City, Guangdong Province, P.R.C. (214101)

Tel: 86-510-88708842 Fax: 86-510-88211895



RoHS Compliant



005

SPECIFICATION OF OSCILLATOR

YOKETAN CORP.

Customer : Qi Hardware

SPEC NO : SO7050-050000-O3A-BBE-QA

Date : 8-Mar-10

1. <u>型名 (Type)</u>	<u>SO7050 (Lead Free Parts)</u>
2. <u>週波數(Frequency)</u>	<u>50.000 MHz</u>
3. <u>電源電壓 (Power supply voltage)</u>	<u>3.3V ± 0.33V</u>
4. <u>週波數安定度(Frequency stability)</u>	<u>± 25ppm</u>
5. <u>溫度範圍(Temperature range)</u>	
5.1 <u>動作溫度範圍(Operating temp. range)</u>	<u>-40to +85 degrees</u>
5.2 <u>儲存溫度(Storage temp.)</u>	<u>-40to +85 degrees</u>
6. <u>驅動能力(Driving ability)</u>	<u>15pF</u>
7. <u>波形對稱性(Symmetry)</u>	<u>40% to 60%</u>
8. <u>立上/立下時間(Rise,fall time)</u>	<u>6 ns(Max.)</u>
9. <u>出力電壓(Output voltage)</u>	
9.1 <u>High Output Voltage</u>	<u>VoH:0.9VDD Min.</u>
9.2 <u>Low Output Voltage</u>	<u>VoL:0.1VDD Max.</u>
10. <u>消費電流(Current consumption)</u>	<u>25mA</u>

Marking

50.000 * YOKE

SPECIFICATION OF OSCILLATOR

YOKETAN CORP.

Dimension

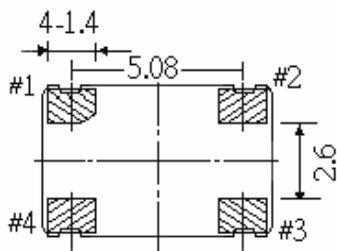
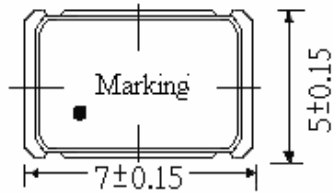

Pin Assignment

- #1 STANDBY CON
- #2 GND
- #3 OUTPUT
- #4 VDD

Pin 1	Output
H/Floating	Enable
L	Standby

Recommended Soldering Pattern

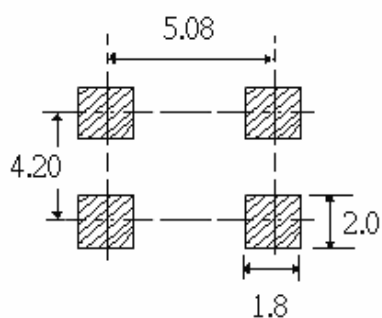

	Date	Name	Unit : mm	
Drawn	12.Sep.2007	Leo	Dimension of External	Drawing No.
Checked	12.Sep.2007	Iris		PKO-705016-012
Approved	12.Sep.2007	Wan		

SPECIFICATION OF OSCILLATOR

YOKETAN CORP.

Test Circuit

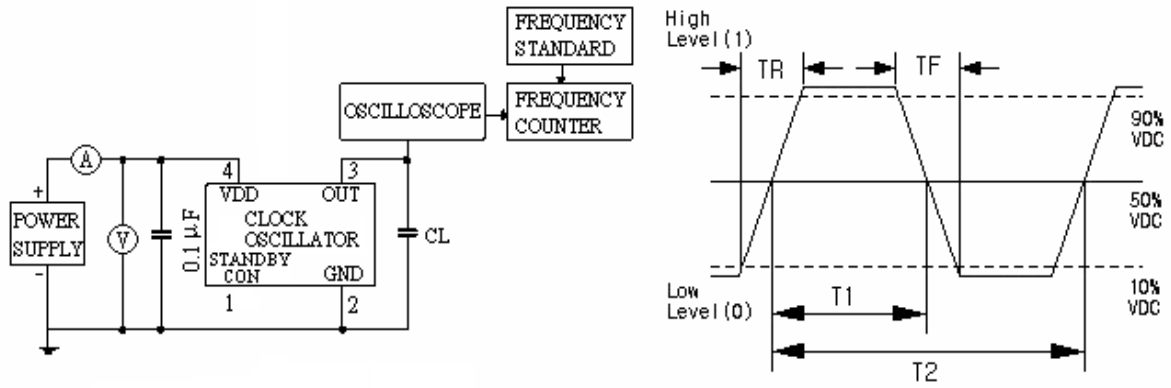

Soldering Reflow

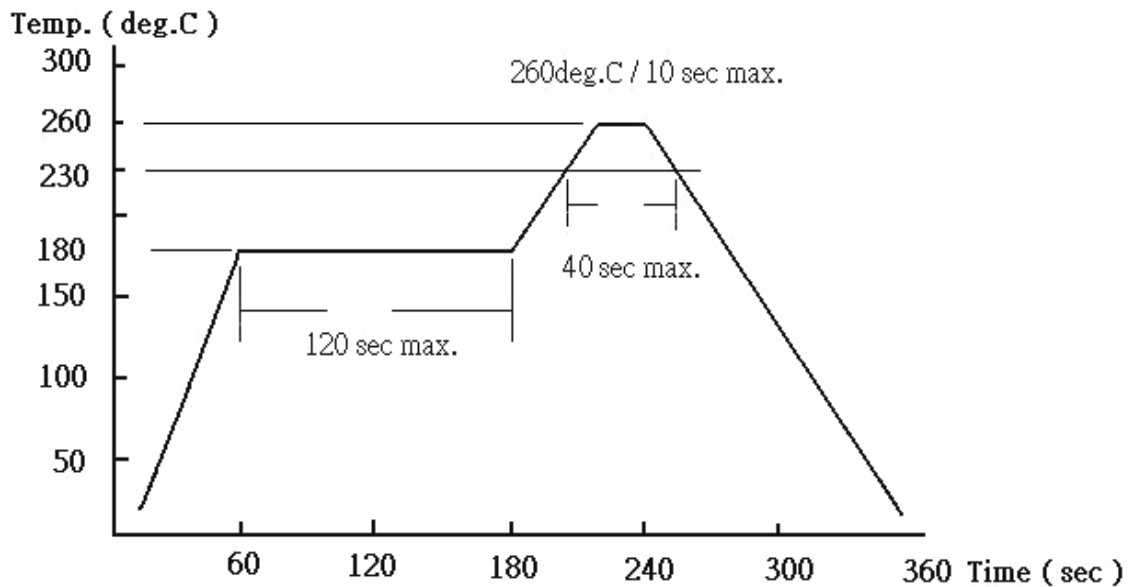

SPECIFICATION OF CRYSTAL & OSC UNITS

YOKETAN CORP.

Reliability Test (applicable to OSC and SMD type X'tal)

Test Items	Test Condition	Specification	
		General OSC (Note:1)	General X'tal (Note:2)
1. Gross Leak Test	FC-40 125 /30sec	No continuous bubble	
2. Fine Leak Test	Bombing of He 5kg/cm ² for 2 hours	Less than 1*10 ⁻⁸ atm.c.c./sec, Helium	
3. Drop Test	a. ~19.999MHz(Fund.) 100 cm height b. 20~29.999MHz(Fund.) 50 cm height c. 30~ MHz(Fund.) 20 cm height on hard wooden surface / 3 times (thickness more than 30 mm)	F ± 10PPM , Duty within spec.	F ±10PPM , C.I. ±10ohms
4. Vibration Test	Freq. range: 10~55Hz Peak to peak amplitude:1.5mm Peak acceleration:10 G 3 direction(X,Y,Z) , each 60min.	F ± 10PPM , Duty within spec.	F ±10PPM , C.I. ±10ohms
5. Resistance to Soldering Test	a. IR Reflow furnace with the condition 2 times.Peak temp.260±3 , 10±1 sec.	F ±10PPM , Duty within spec. For SMD OSC only	F ±10PPM , C.I. ±10ohms
	b. Dip terminals in a 260±5 solder bath for 5±1 sec.	At least 90% by 30X magnification of each dipped area shall be covered by fresh solder. For DIP OSC only.	NA
6. Bending Test	Bending cycle : 1 cycle 0° -> 45° -> 0° -> 45° -> 0°	F ±5PPM , Duty within spec. For DIP OSC only.	NA
7. Shearing Test	Weight : 5N, Test duration : 10±1 sec	F ±5PPM , Duty within spec. For SMD OSC only.	F ±10PPM , C.I. ±10ohms
8. Low Temp. Exposure Test	-40±3 , 240±12 hrs	F ±10PPM , Duty within spec.	F ±10PPM , C.I. ±10ohms
9. Aging Test	125±3 , 240±12hrs	F ±10PPM , Duty within spec.	F ±10PPM , C.I. ±10ohms
10. High Temp. & Humidity Test	+85 ±5 & 85%±5% R.H. , 240±12 hrs	F ±10PPM , Duty within spec.	F ±10PPM , C.I. ±10ohms
11. Temperature Cycling Test	-40±3 /15±3min ~ +85±3 /15±3min 15cycles	F ±10PPM , Duty within spec.	F ±10PPM , C.I. ±10ohms

Note:1 For communication application the spec. demanded “ F ±5 PPM, Duty within spec.”.

Note:2 For communication application the spec. demanded “ F ±5 PPM, C.I. ±5 ohms”.

Taping

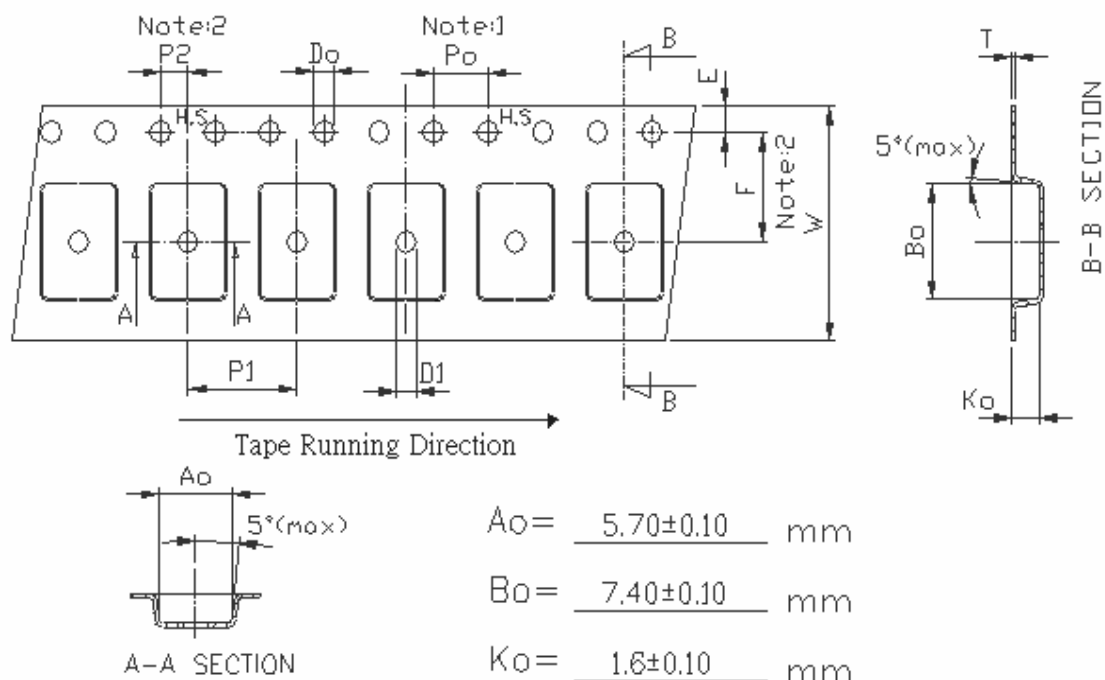

Unit: mm

Symbol	Spec.
K1	-
Po	4.00±0.10
P1	8.00±0.10
P2	2.00±0.10
Do	1.50 ^{+0.1} ₀
D1	1.50(min)
E	1.75±0.10
F	7.50±0.10
10Po	40.0±0.10
W	16.0±0.30
T	0.30±0.05

Notice:

1. 10 Sprocket hole pitch cumulative tolerance is ±0.10 mm
2. Pocket position relative to sprocket hole measured as true position of pocket not pocket hole.
3. Ao & Bo measured on a place 0.3mm above the bottom of the pocket to top surface of the carrier.
4. Ko measured from a plane on the inside bottom of the pocket to the top surface of the carrier.
5. Carrier camber shall be not than 1mm per 100mm through a length of 250mm.

	Date	Name	Unit : mm	
Drawn	20.Jan.2007	Leo	Title Tape & Reel Dimension	Drawing No. C009-050716-A-1101
Checked	20.Jan.2007	Iris		
Approved	20.Jan.2007	Wan		

SPECIFICATION OF TAPE & REEL

YOKETAN CORP.

Reel

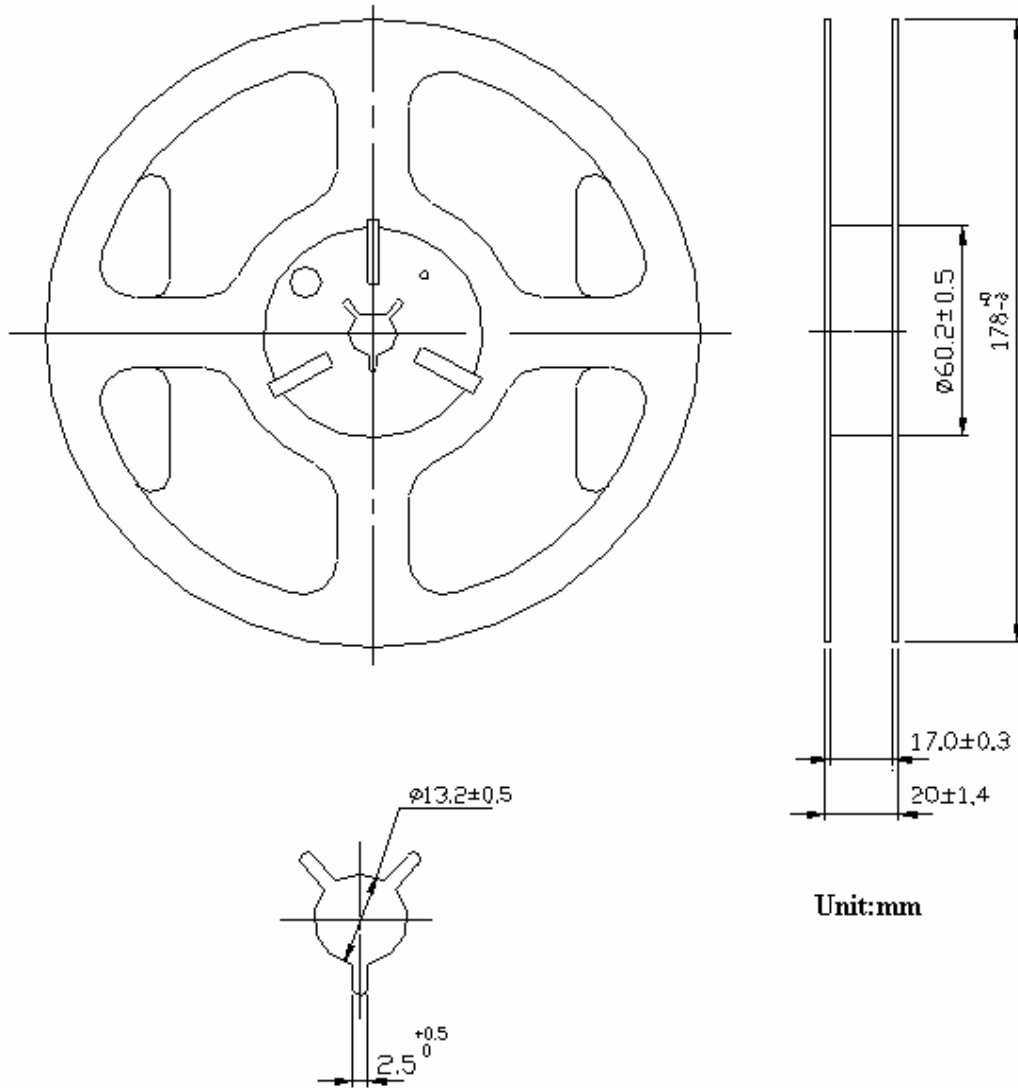

Unit:mm

Q'ty:1000pcs/reel

	Date	Name	Unit : mm	
Drawn	20.Jan.2007	Leo	Title Tape & Reel Dimension	Drawing No. C009-0717-A-0201
Checked	20.Jan.2007	Iris		
Approved	20.Jan.2007	Wan		

Test Report

No. : CE/2009/B7174 Date : 2009/12/07 Page : 1 of 8

YOKETAN CORPORATION
28-2, NAN 2ND ROAD, T. E. P. Z, TAICHUNG, TAIWAN



The following sample(s) was/were submitted and identified by/on behalf of the client as :

Sample Description : OSCILLATOR UNIT
Style/Item No. : SOXX & SV(T)XX & LVXX SERIES
Sample Receiving Date : 2009/11/30
Testing Period : 2009/11/30 TO 2009/12/07

=====
Test Result(s) : Please refer to next page(s).

Chenyu Kung / Operation Manager
Signed for and on behalf of
SGS TAIWAN LTD.
Chemical Laboratory – Taipei

Unless otherwise stated the results shown in this test report refer only to the sample(s) tested. This test report cannot be reproduced, except in full, without prior written permission of the Company.
除非另有說明，此報告結果僅針對測試之樣品負責。本報告未經本公司書面許可，不可部分複製。
This Test Report is issued by the Company under its General Conditions of Service printed overleaf or available on request and accessible at http://www.sgs.com/terms_and_conditions.htm. Attention is drawn to the limitation of liability, indemnification and jurisdiction issues defined therein. Any holder of this Test Report is advised that information contained herein reflects the Company's findings at the time of its intervention only and within the limits of Client's instructions, if any. The Company's sole responsibility is to its Client and this document does not exonerate parties to a transaction from exercising all their rights and obligations under the transaction documents. Any unauthorized alteration, forgery or falsification of the content or appearance of this document is unlawful and offenders may be prosecuted to the fullest extent of the law.

Test Report

No. : CE/2009/B7174 Date : 2009/12/07 Page : 2 of 8

YOKETAN CORPORATION
28-2, NAN 2ND ROAD, T. E. P. Z, TAICHUNG, TAIWAN



Test Result(s)

PART NAME NO.1 : MIXED ALL PARTS (SEVEN TYPES)

Test Item (s):	Unit	Method	MDL	Result
				No.1
Cadmium (Cd)	mg/kg	With reference to IEC 62321: 2008 and performed by ICP-AES.	2	n.d.
Lead (Pb)	mg/kg	With reference to IEC 62321: 2008 and performed by ICP-AES.	2	n.d.
Mercury (Hg)	mg/kg	With reference to IEC 62321: 2008 and performed by ICP-AES.	2	n.d.
Hexavalent Chromium Cr(VI) by alkaline extraction	mg/kg	With reference to IEC 62321: 2008 and performed by UV-VIS.	2	n.d.
Perfluorooctane sulfonates (PFOS) PFOS – Acid PFOS – Metal Salt PFOS – Amide	mg/kg	With reference to US EPA 3540C: 1996 method for PFOS Content. Analysis was performed by LC/MS.	10	n.d.
PFOA (CAS No.: 000335-67-1)	mg/kg	With reference to US EPA 3540C: 1996 method for PFOA Content. Analysis was performed by LC/MS.	10	n.d.
Sum of PBBs	mg/kg	With reference to IEC 62321: 2008 and performed by GC/MS.	-	n.d.
Monobromobiphenyl			5	n.d.
Dibromobiphenyl			5	n.d.
Tribromobiphenyl			5	n.d.
Tetrabromobiphenyl			5	n.d.
Pentabromobiphenyl			5	n.d.
Hexabromobiphenyl			5	n.d.
Heptabromobiphenyl			5	n.d.
Octabromobiphenyl			5	n.d.
Nonabromobiphenyl			5	n.d.
Decabromobiphenyl			5	n.d.

Unless otherwise stated the results shown in this test report refer only to the sample(s) tested. This test report cannot be reproduced, except in full, without prior written permission of the Company.
除非另有說明，此報告結果僅針對測試之樣品負責。本報告未經本公司書面許可，不可部分複製。
This Test Report is issued by the Company under its General Conditions of Service printed overleaf or available on request and accessible at http://www.sgs.com/terms_and_conditions.htm. Attention is drawn to the limitation of liability, indemnification and jurisdiction issues defined therein. Any holder of this Test Report is advised that information contained herein reflects the Company's findings at the time of its intervention only and within the limits of Client's instructions, if any. The Company's sole responsibility is to its Client and this document does not exonerate parties to a transaction from exercising all their rights and obligations under the transaction documents. Any unauthorized alteration, forgery or falsification of the content or appearance of this document is unlawful and offenders may be prosecuted to the fullest extent of the law.

Test Report

No. : CE/2009/B7174 Date : 2009/12/07 Page : 3 of 8

YOKETAN CORPORATION
28-2, NAN 2ND ROAD, T. E. P. Z, TAICHUNG, TAIWAN



Test Item (s):	Unit	Method	MDL	Result
				No.1
Sum of PBDEs	mg/kg	With reference to IEC 62321: 2008 and performed by GC/MS.	-	n.d.
Monobromodiphenyl ether			5	n.d.
Dibromodiphenyl ether			5	n.d.
Tribromodiphenyl ether			5	n.d.
Tetrabromodiphenyl ether			5	n.d.
Pentabromodiphenyl ether			5	n.d.
Hexabromodiphenyl ether			5	n.d.
Heptabromodiphenyl ether			5	n.d.
Octabromodiphenyl ether			5	n.d.
Nonabromodiphenyl ether			5	n.d.
Decabromodiphenyl ether			5	n.d.
Halogen			mg/kg	With reference to BS EN 14582:2007. Analysis was performed by IC.
Halogen-Fluorine (F) (CAS No.: 014762-94-8)	50	n.d.		
Halogen-Chlorine (Cl) (CAS No.: 022537-15-1)	50	n.d.		
Halogen-Bromine (Br) (CAS No.: 010097-32-2)	50	n.d.		
Halogen-Iodine (I) (CAS No.: 014362-44-8)			50	n.d.

- Note :
1. mg/kg = ppm; 0.1wt% = 1000ppm
 2. n.d. = Not Detected
 3. MDL = Method Detection Limit
 4. " - " = Not Regulated
 5. The sample(s) was/were analyzed on behalf of the applicant as mixing sample in one testing.
The above result(s) was/were only given as the informality value.

PFOS Reference Information : Directive 2006/122/EC

- (1) May not be placed on the market or used as a substance or constituent of preparations in a concentration equal to or higher than 0.005 % by mass.
- (2) May not be placed on the market in semi-finished products or articles, or parts thereof, if the concentration of PFOS is equal to or higher than 0.1 % by mass calculated with reference to the mass of structurally or microstructurally distinct parts that contain PFOS or, for textiles or other coated materials, if the amount of PFOS is equal to or higher than 1µg/m² of the coated material.

Unless otherwise stated the results shown in this test report refer only to the sample(s) tested. This test report cannot be reproduced, except in full, without prior written permission of the Company.
除非另有說明，此報告結果僅針對測試之樣品負責。本報告未經本公司書面許可，不可部分複製。
This Test Report is issued by the Company under its General Conditions of Service printed overleaf or available on request and accessible at http://www.sgs.com/terms_and_conditions.htm. Attention is drawn to the limitation of liability, indemnification and jurisdiction issues defined therein. Any holder of this Test Report is advised that information contained herein reflects the Company's findings at the time of its intervention only and within the limits of Client's instructions, if any. The Company's sole responsibility is to its Client and this document does not exonerate parties to a transaction from exercising all their rights and obligations under the transaction documents. Any unauthorized alteration, forgery or falsification of the content or appearance of this document is unlawful and offenders may be prosecuted to the fullest extent of the law.

Test Report

No. : CE/2009/B7174 Date : 2009/12/07 Page : 4 of 8

YOKETAN CORPORATION
28-2, NAN 2ND ROAD, T. E. P. Z, TAICHUNG, TAIWAN



- 1) These samples were dissolved totally by pre-conditioning method according to below flow chart.
(Cr⁶⁺ test method excluded)
- 2) Name of the person who made measurement: Climbgreat Yang
- 3) Name of the person in charge of measurement: Troy Chang

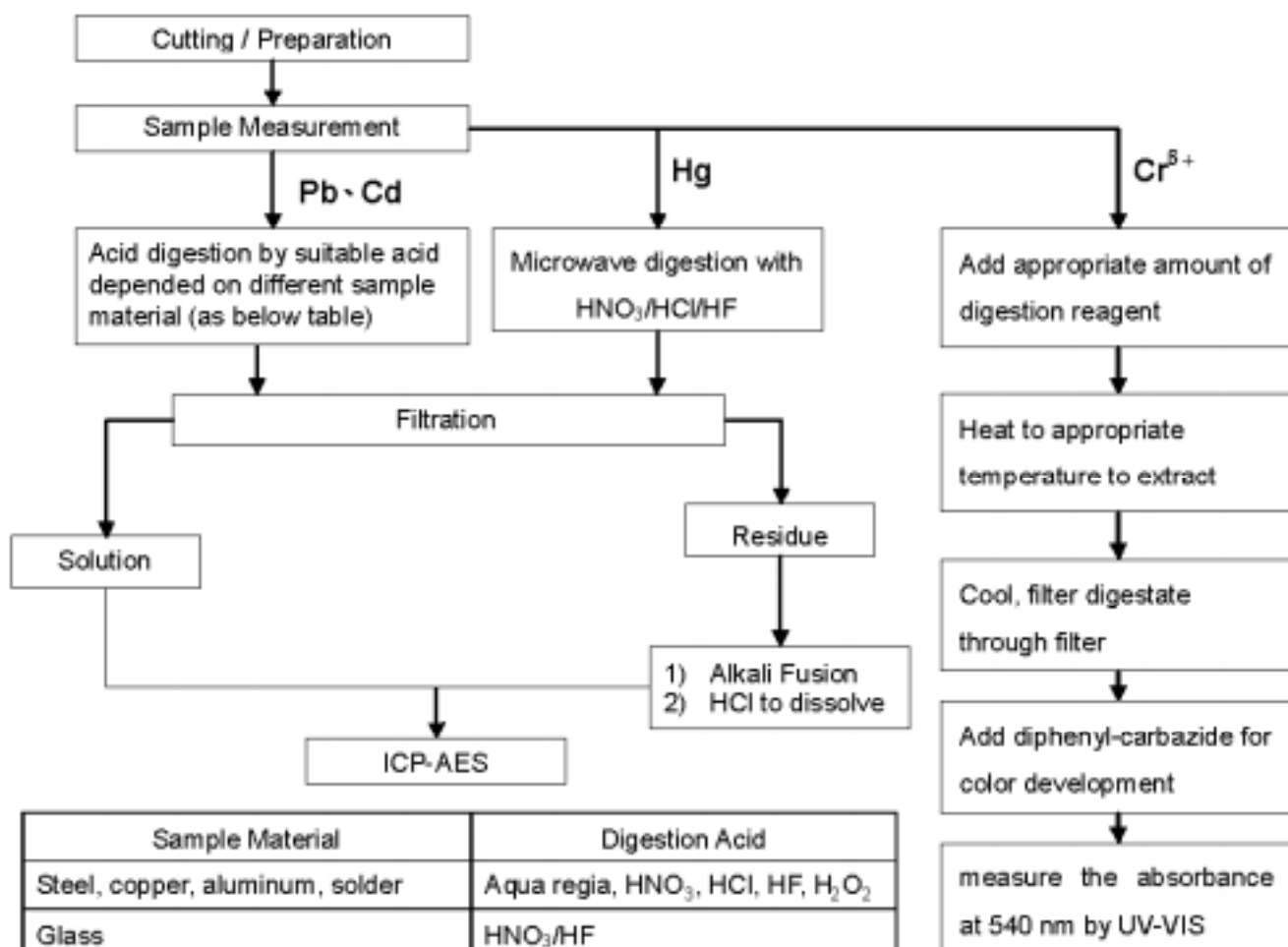

Sample Material	Digestion Acid
Steel, copper, aluminum, solder	Aqua regia, HNO ₃ , HCl, HF, H ₂ O ₂
Glass	HNO ₃ /HF
Gold, platinum, palladium, ceramic	Aqua regia
Silver	HNO ₃
Plastic	H ₂ SO ₄ , H ₂ O ₂ , HNO ₃ , HCl
Others	Any acid to total digestion

Unless otherwise stated the results shown in this test report refer only to the sample(s) tested. This test report cannot be reproduced, except in full, without prior written permission of the Company.
 除非另有說明，此報告結果僅針對測試之樣品負責。本報告未經本公司書面許可，不可部分複製。
 This Test Report is issued by the Company under its General Conditions of Service printed overleaf or available on request and accessible at http://www.sgs.com/terms_and_conditions.htm. Attention is drawn to the limitation of liability, indemnification and jurisdiction issues defined therein. Any holder of this Test Report is advised that information contained herein reflects the Company's findings at the time of its intervention only and within the limits of Client's instructions, if any. The Company's sole responsibility is to its Client and this document does not exonerate parties to a transaction from exercising all their rights and obligations under the transaction documents. Any unauthorized alteration, forgery or falsification of the content or appearance of this document is unlawful and offenders may be prosecuted to the fullest extent of the law.



Analytical flow chart of Soxhlet extraction (LC/MS) procedure

- 1) Name of the person who made measurement: Lydia Fu
- 2) Name of the person in charge of measurement: Shinjyh Chen

■ Test Items: PFOS/PFOA · Benzotriazole

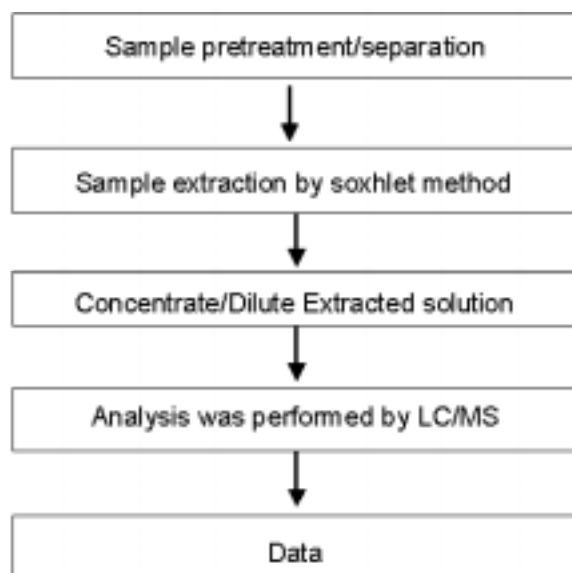

Unless otherwise stated the results shown in this test report refer only to the sample(s) tested. This test report cannot be reproduced, except in full, without prior written permission of the Company.
 除非另有註明，此報告結果僅針對測試之樣品負責。本報告未經本公司書面許可，不可部分複製。
 This Test Report is issued by the Company under its General Conditions of Service printed overleaf or available on request and accessible at http://www.sgs.com/terms_and_conditions.htm. Attention is drawn to the limitation of liability, indemnification and jurisdiction issues defined therein. Any holder of this Test Report is advised that information contained herein reflects the Company's findings at the time of its intervention only and within the limits of Client's instructions, if any. The Company's sole responsibility is to its Client and this document does not exonerate parties to a transaction from exercising all their rights and obligations under the transaction documents. Any unauthorized alteration, forgery or falsification of the content or appearance of this document is unlawful and offenders may be prosecuted to the fullest extent of the law.



PBB/PBDE analytical FLOW CHART

- 1) Name of the person who made measurement: Roman Wong
- 2) Name of the person in charge of measurement: Shinjyh Chen

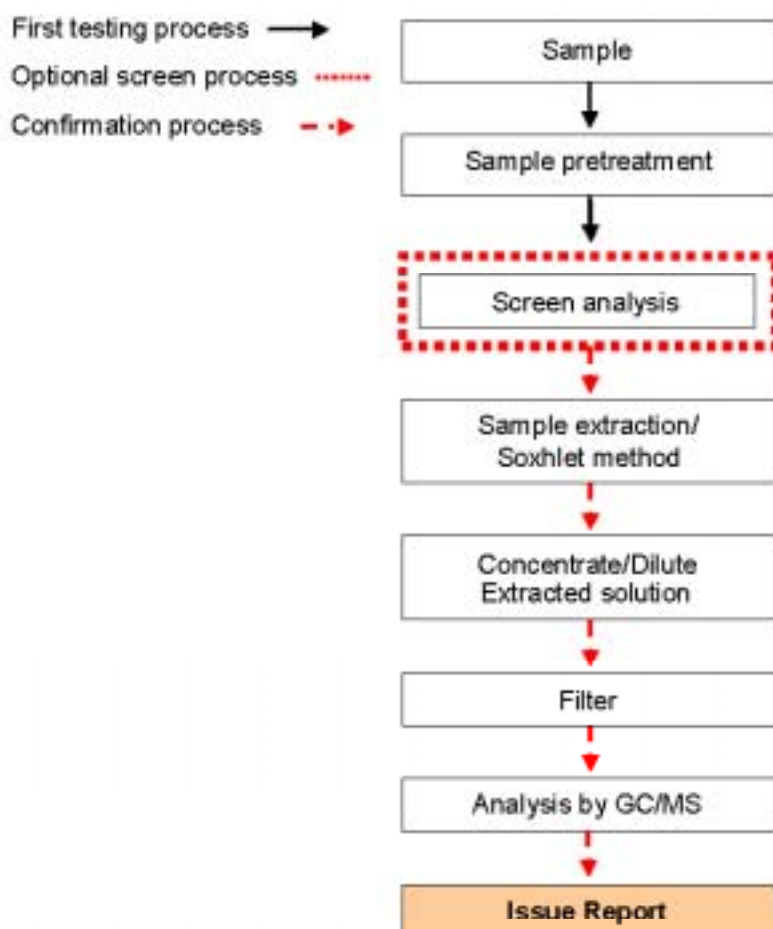

Unless otherwise stated the results shown in this test report refer only to the sample(s) tested. This test report cannot be reproduced, except in full, without prior written permission of the Company.
 除非另有註明，此報告結果僅針對圖中之樣品負責。本報告未經本公司書面許可，不可部分複製。
 This Test Report is issued by the Company under its General Conditions of Service printed overleaf or available on request and accessible at http://www.sgs.com/terms_and_conditions.htm. Attention is drawn to the limitation of liability, indemnification and jurisdiction issues defined therein. Any holder of this Test Report is advised that information contained herein reflects the Company's findings at the time of its intervention only and within the limits of Client's instructions, if any. The Company's sole responsibility is to its Client and this document does not exonerate parties to a transaction from exercising all their rights and obligations under the transaction documents. Any unauthorized alteration, forgery or falsification of the content or appearance of this document is unlawful and offenders may be prosecuted to the fullest extent of the law.

Test Report

No. : CE/2009/B7174 Date : 2009/12/07 Page : 7 of 8

YOKETAN CORPORATION
28-2, NAN 2ND ROAD, T. E. P. Z, TAICHUNG, TAIWAN



Analytical flow chart of halogen content

- 1) Name of the person who made measurement: Alan Chen
- 2) Name of the person in charge of measurement: Troy Chang

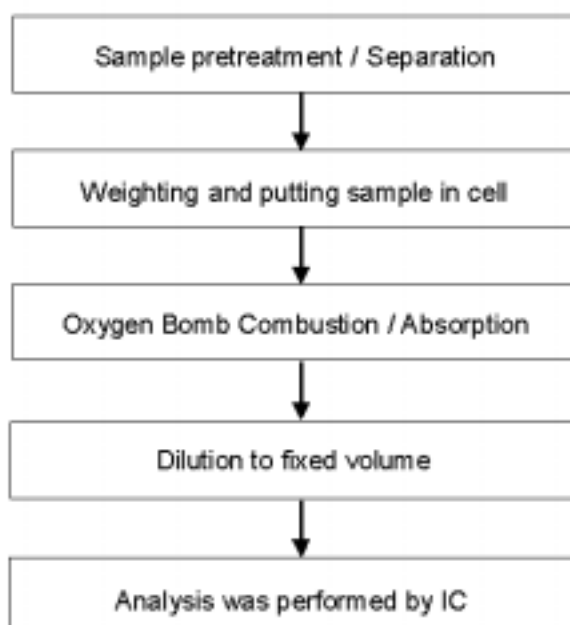

Unless otherwise stated the results shown in this test report refer only to the sample(s) tested. This test report cannot be reproduced, except in full, without prior written permission of the Company.
 除非另有說明，此報告結果僅針對測試之樣品負責。本報告未經本公司書面許可，不可部分複製。
 This Test Report is issued by the Company under its General Conditions of Service printed overleaf or available on request and accessible at http://www.sgs.com/terms_and_conditions.htm. Attention is drawn to the limitation of liability, indemnification and jurisdiction issues defined therein. Any holder of this Test Report is advised that information contained herein reflects the Company's findings at the time of its intervention only and within the limits of Client's instructions, if any. The Company's sole responsibility is to its Client and this document does not exonerate parties to a transaction from exercising all their rights and obligations under the transaction documents. Any unauthorized alteration, forgery or falsification of the content or appearance of this document is unlawful and offenders may be prosecuted to the fullest extent of the law.

Test Report

No. : CE/2009/B7174 Date : 2009/12/07 Page : 8 of 8

YOKETAN CORPORATION
28-2, NAN 2ND ROAD, T. E. P. Z, TAICHUNG, TAIWAN



** End of Report **

Unless otherwise stated the results shown in this test report refer only to the sample(s) tested. This test report cannot be reproduced, except in full, without prior written permission of the Company.
除非另有說明，此報告結果僅針對圖中之樣品負責。本報告未經本公司書面許可，不可部分複製。
This Test Report is issued by the Company under its General Conditions of Service printed overleaf or available on request and accessible at http://www.sgs.com/terms_and_conditions.htm. Attention is drawn to the limitation of liability, indemnification and jurisdiction issues defined therein. Any holder of this Test Report is advised that information contained herein reflects the Company's findings at the time of its intervention only and within the limits of Client's instructions, if any. The Company's sole responsibility is to its Client and this document does not exonerate parties to a transaction from exercising all their rights and obligations under the transaction documents. Any unauthorized alteration, forgery or falsification of the content or appearance of this document is unlawful and offenders may be prosecuted to the fullest extent of the law.