

---

**Features**

---

- 1.3V maximum dropout at full load current
- Fixed  $1.2V \pm 2\%$  output voltage
- Fast transient response
- Output current limiting
- Built-in thermal shutdown
- Good noise rejection
- Packages: SOT223-3L, TO252-3L, SOT89-3L, TO263-3L and TO220-3L
- SOT223-3L and TO252-3L: Available in "Green" Molding Compound (No Br, Sb)
- Lead Free Finish/RoHS Compliant (Note 2)

---

**General Description**

---

AP1122 is a low dropout positive fixed-mode regulator with 1A output current capability. The product is specifically designed to provide well-regulated supply for low voltage IC applications such as high-speed bus termination and low current 1.2V logic supply. AP1122 is also well suited for other applications such as VGA cards. AP1122 is guaranteed to have lower than 1.3V dropout at full load current making it ideal to provide well-regulated outputs of 1.2 output voltage with 2.5V input voltage supply.

---

**Applications**

---

- PC peripheral
- Communication

---





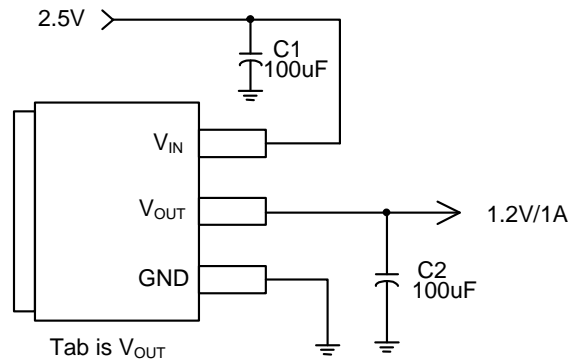



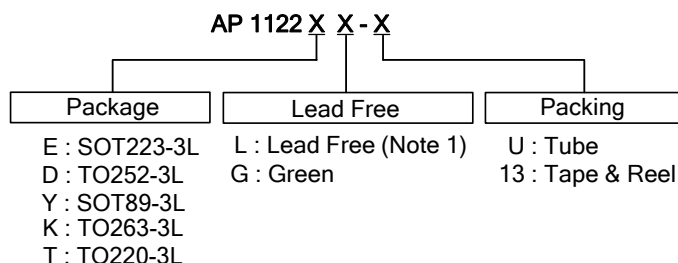



**Typical Application Circuit**

---



### Ordering Information



Device	Package Code	Packaging (Note 3)	Tube		13" Tape and Reel	
			Quantity	Part Number Suffix	Quantity	Part Number Suffix
 AP1122EG-U	E	SOT223-3L	75	-U	NA	NA
 AP1122EG-13	E	SOT223-3L	NA	NA	2500/Tape & Reel	-13
 AP1122EL-U	E	SOT223-3L	75	-U	NA	NA
 AP1122EL-13	E	SOT223-3L	NA	NA	2500/Tape & Reel	-13
 AP1122DG-U	D	TO252-3L	80	-U	NA	NA
 AP1122DG-13	D	TO252-3L	NA	NA	2500/Tape & Reel	-13
 AP1122DL-U	D	TO252-3L	80	-U	NA	NA
 AP1122DL-13	D	TO252-3L	NA	NA	2500/Tape & Reel	-13
 AP1122YL-13	Y	SOT89-3L	NA	NA	2500/Tape & Reel	-13
 AP1122KL-U	K	TO263-3L	50	-U	NA	NA
 AP1122KL-13	K	TO263-3L	NA	NA	800/Tape & Reel	-13
 AP1122TL-U	T	TO220-3L	50	-U	NA	NA

- Notes:
- SOT89-3L, TO263-3L and TO220-3L are available in "Lead Free" products only.
  - EU Directive 2002/95/EC (RoHS). All applicable RoHS exemptions applied. Please visit our website at [http://www.diodes.com/products/lead\\_free.html](http://www.diodes.com/products/lead_free.html)
  - Pad layout as shown on Diodes Inc. suggested pad layout document AP02001, which can be found on our website at <http://www.diodes.com/datasheets/ap02001.pdf>.

**Pin Assignment**

(1) SOT223-3L

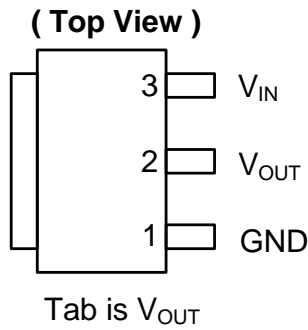

(2) TO252-3L/ TO263-3L

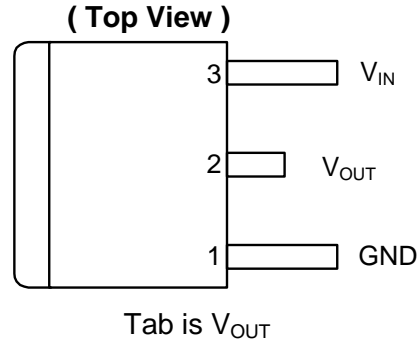

(3) SOT89-3L

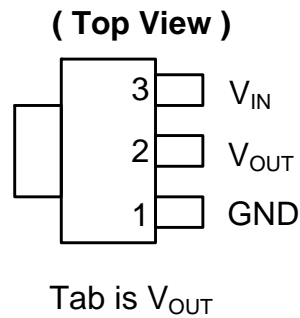

(4) TO220-3L

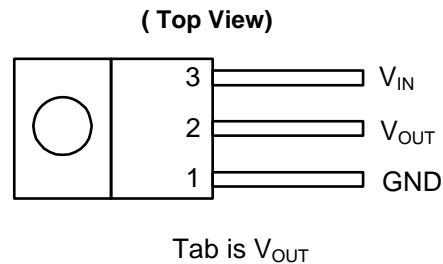

**Pin Descriptions**

Pin Name	I/O	Pin #	Description
GND	I	1	Ground Pin
$V_{OUT}$	O	2	The output of the regulator. A minimum of 10uF capacitor ( $0.15\Omega \leq ESR \leq 20\Omega$ ) must be connected from this pin to ground to insure stability.
$V_{IN}$	I	3	The input pin of regulator. Typically a large storage capacitor is connected from this pin to ground to insure that the input voltage does not sag below the minimum dropout voltage during the load transient response.

**Block Diagram**

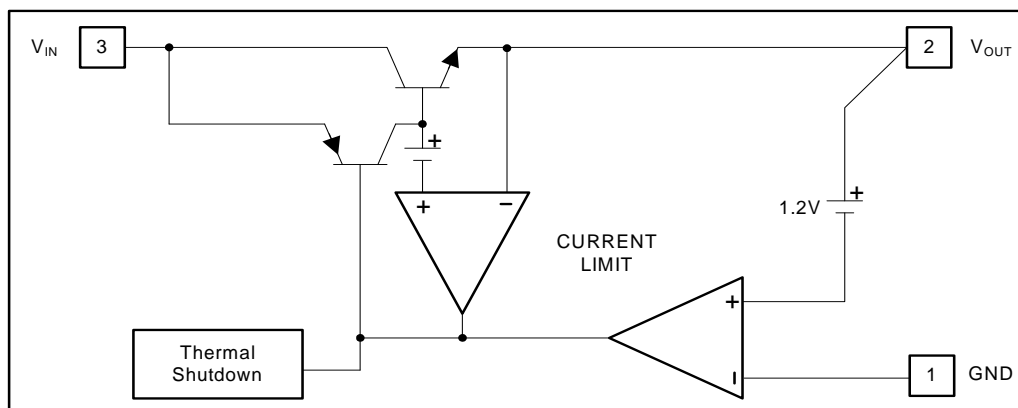

**Absolute Maximum Ratings**

Symbol	Parameter	Rating	Unit
$V_{IN}$	DC Supply Voltage	-0.3 to 12	V
$T_{ST}$	Storage Temperature	-65 to +150	°C
$T_{MJ}$	Maximum Junction Temperature	150	°C

**Recommended Operating Conditions**

Symbol	Parameter	Min	Max	Unit
$I_{OUT}$	Output Current	-	1.0	A
$T_{OP}$	Operating Junction Temperature Range	0	125	°C

### Electrical Characteristics (Under Operating Conditions)

Parameter	Conditions	Min	Typ.	Max	Unit
Output Voltage	$2.5V \leq V_{IN} \leq 12V$ , $I_O=10mA$ , $T_A=25^\circ C$	1.176	1.2	1.224	V
Line Regulation	$2.5V \leq V_{IN} \leq 12V$ , $I_O=10mA$ , $T_A=25^\circ C$			0.2	%
Load Regulation	$V_{IN}=2.5V \sim 12V$ , $10mA < I_O < 1A$ , $T_A=25^\circ C$ (Note 4, 5)			1	%
Dropout Voltage ( $V_{IN}-V_{OUT}$ )	$I_{OUT} = 1A$ , $\Delta V_{OUT} = 1\%V_{OUT}$			1.3	V
Current Limit	$(V_{IN}-V_{OUT}) = 5V$	1.1			A
Minimum Load Current (Note 6)	$0^\circ C \leq T_J \leq 125^\circ C$		5	10	mA
Thermal Regulation	$T_A=25^\circ C$ , 30ms pulse		0.008	0.04	%/W
Ripple Rejection	$F=120Hz$ , $C_{OUT}=25\mu F$ Tantalum, $I_{OUT}=1A$ , $V_{IN}=V_{OUT}+3V$		60	70	dB
Temperature Stability	$I_O=10mA$		0.5		%
$\theta_{JA}$ Thermal Resistance Junction-to-Ambient	SOT89-3L: Control Circuitry/Power Transistor (Note 7)		182		°C/W
	SOT223-3L: Control Circuitry/Power Transistor (Note 8)		107		
	TO252-3L: Control Circuitry/Power Transistor (Note 7)		73		
	TO220-3L: Control Circuitry/Power Transistor (Note 7)		78		
	TO263-3L: Control Circuitry/Power Transistor (Note 7)		60		
$\theta_{JC}$ Thermal Resistance Junction-to-Case	SOT89-3L: Control Circuitry/Power Transistor (Note 7)		42		°C/W
	SOT223-3L: Control Circuitry/Power Transistor (Note 8)		16		
	TO252-3L: Control Circuitry/Power Transistor (Note 7)		12		
	TO220-3L: Control Circuitry/Power Transistor (Note 7)		3.5		
	TO263-3L: Control Circuitry/Power Transistor (Note 7)		3.5		

- Notes:
- See thermal regulation specifications for changes in output voltage due to heating effects. Line and load regulation are measured at a constant junction temperature by low duty cycle pulse testing. Load regulation is measured at the output lead = 1/18" from the package.
  - Line and load regulation are guaranteed up to the maximum power dissipation of 15W. Power dissipation is determined by the difference between input and output differential and the output current. Guaranteed maximum power dissipation will not be available over the full input/output range.
  - Quiescent current is defined as the minimum output current required in maintaining regulation. At 12V input/output differential the device is guaranteed to regulate if the output current is greater than 10mA.
  - Test conditions for SOT89-3L, TO252-3L, TO220-3L, and TO263-3L: Devices mounted on FR-4 substrate, single sided PC board, 2oz copper, with minimum recommended pad layout, no air flow.
  - Test condition for SOT223-3L: Device mounted on FR-4 substrate, single sided PC board, 2oz copper, with 5mmX5mm thermal pad layout, no air flow.

**Typical Performance Characteristics**

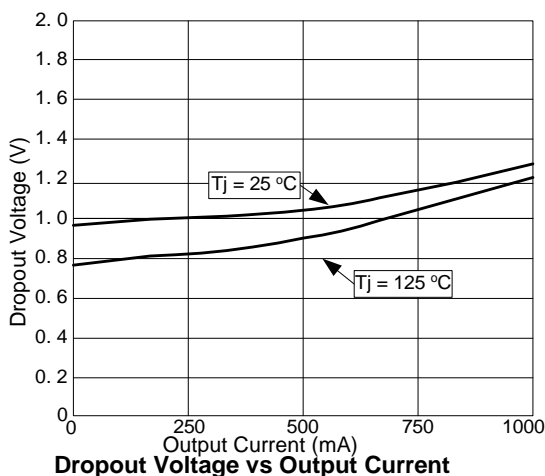

**Dropout Voltage vs Output Current**

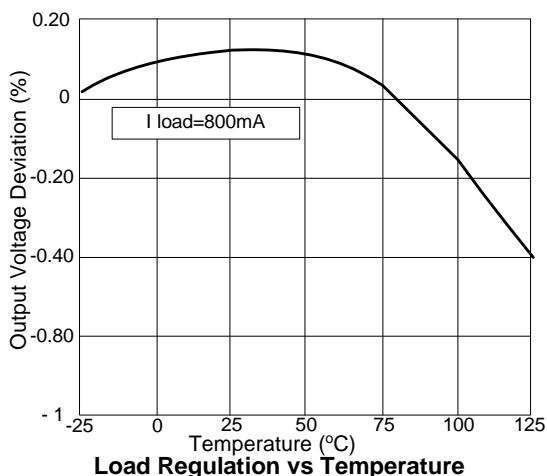

**Load Regulation vs Temperature**

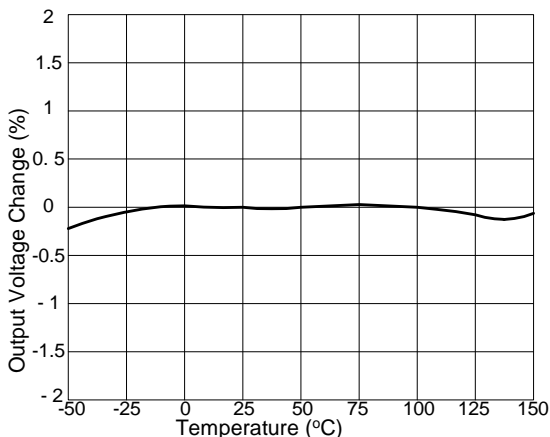

**Percent Change in Output Voltage vs Temperature**

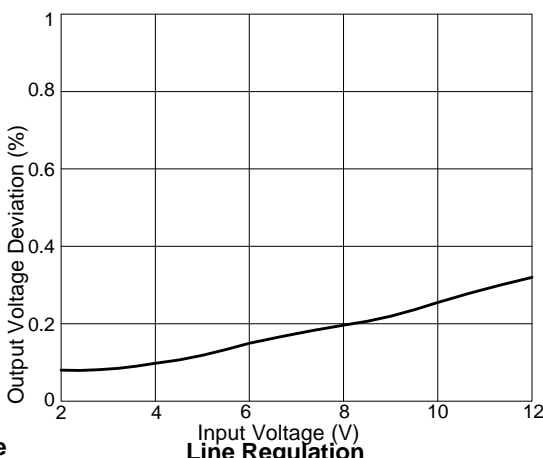

**Line Regulation**

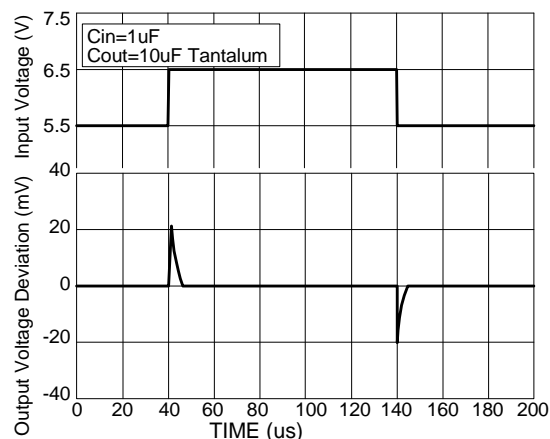

**Line Transient Response**

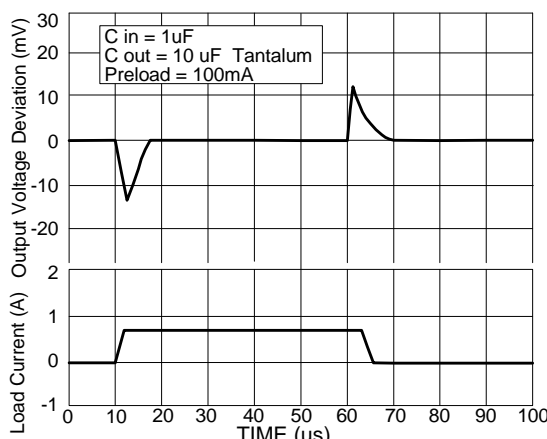

**Load Transient Response**

### Marking Information

#### (1) SOT223-3L

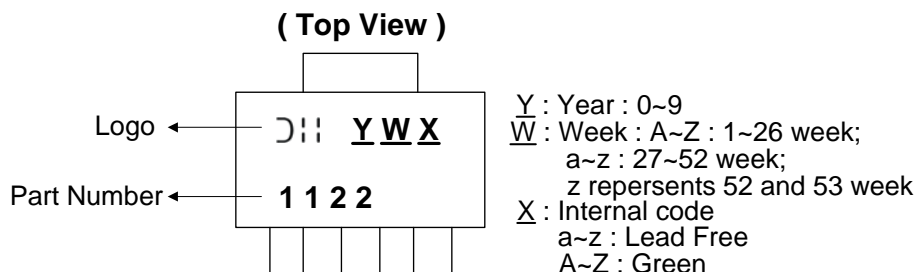

#### (2) TO252-3L

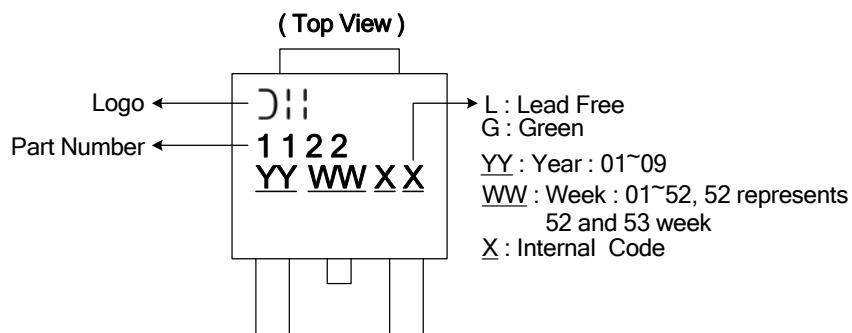

#### (3) SOT89-3L

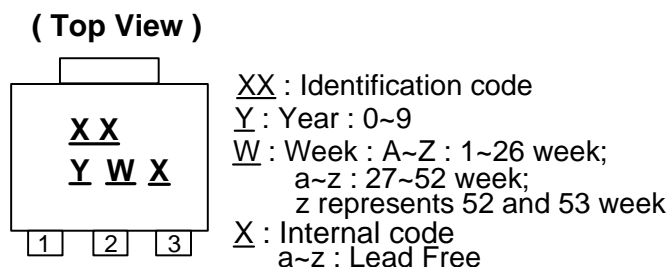

**Marking Code Table**

Identification code	Output version
JB	AP1122

**Marking Information (Continued)**

**(4) TO263-3L**

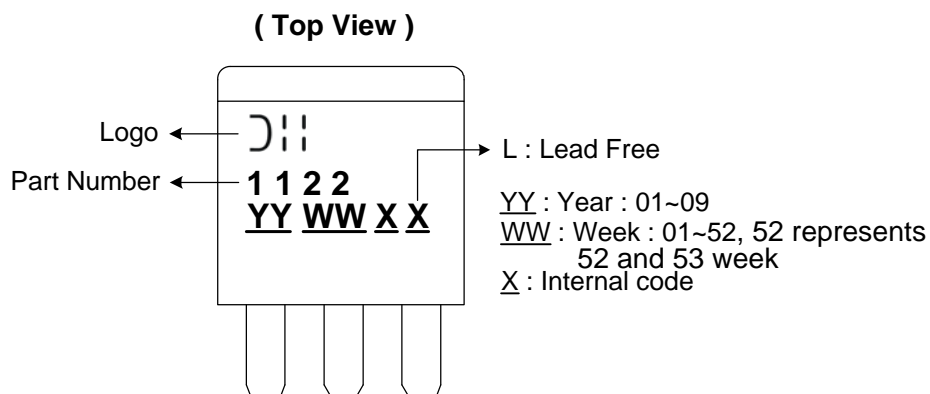

**(5) TO220-3L**

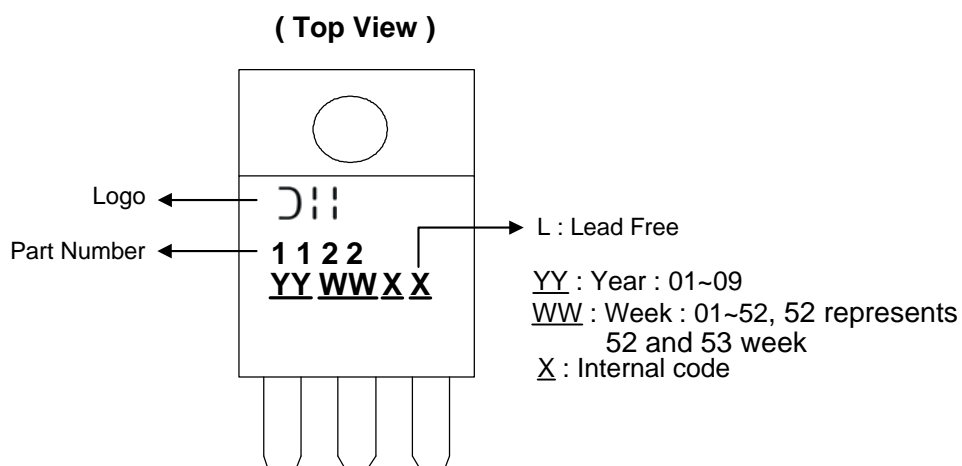



**Package Information (All Dimensions in mm)**

**(1) SOT223-3L**

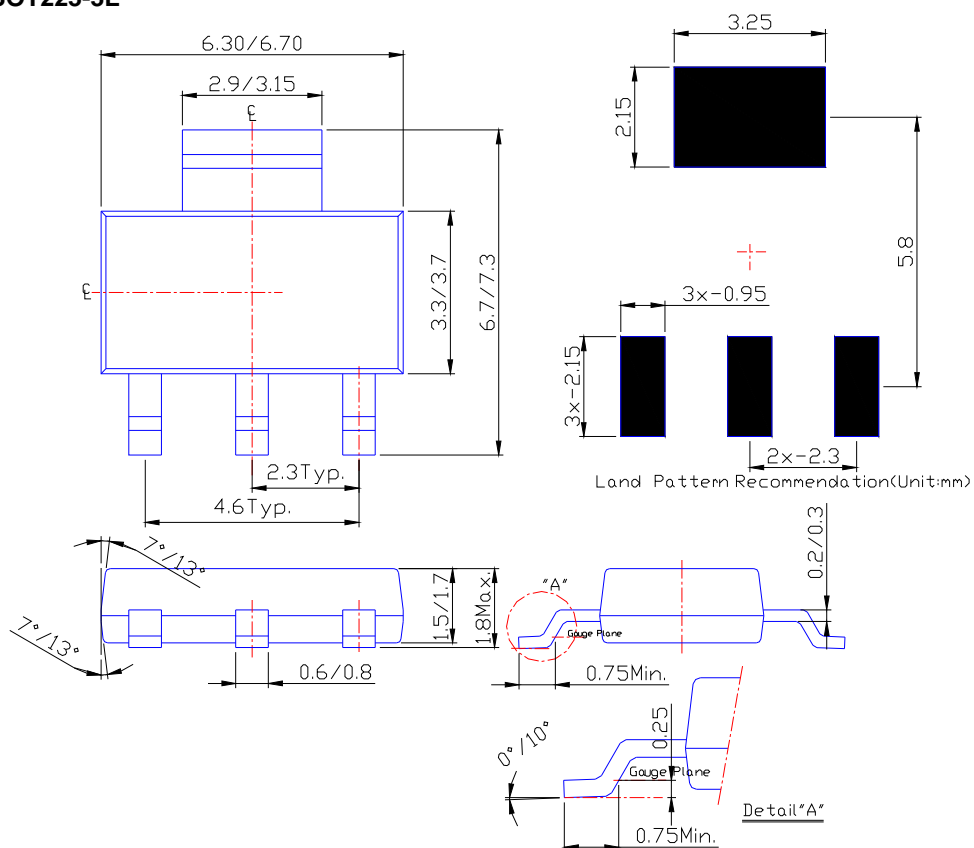

**Package Information (Continued)**

**(2) TO252-3L**

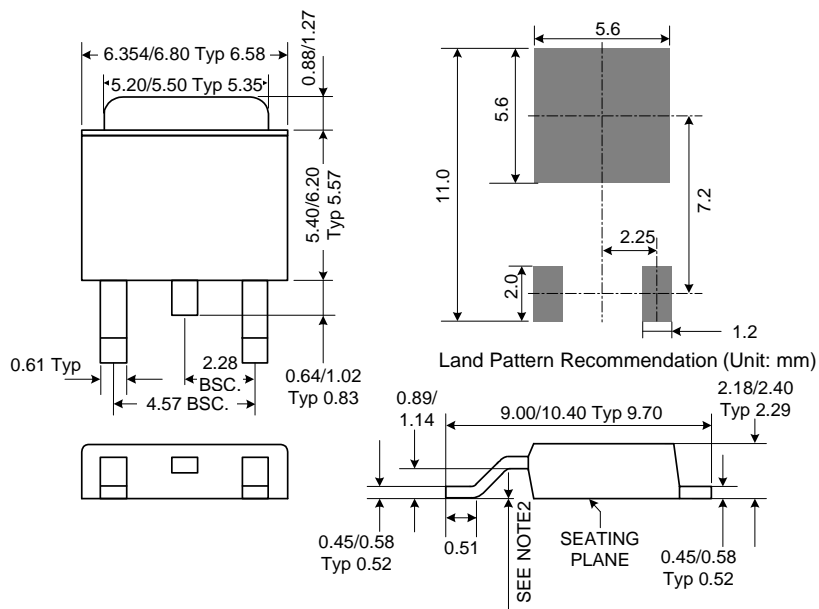

**(3) SOT89-3L**

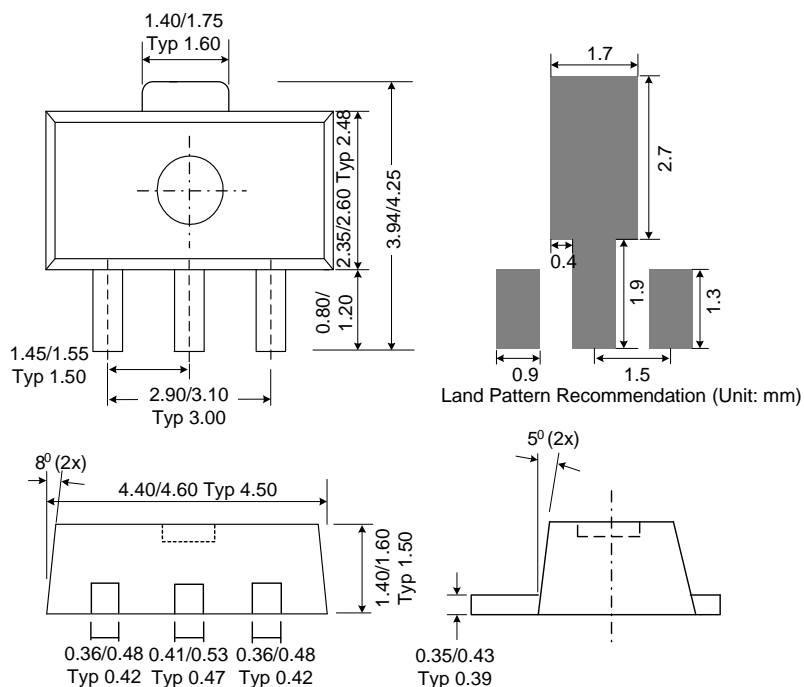

**Package Information (Continued)**

**(4) TO263-3L**

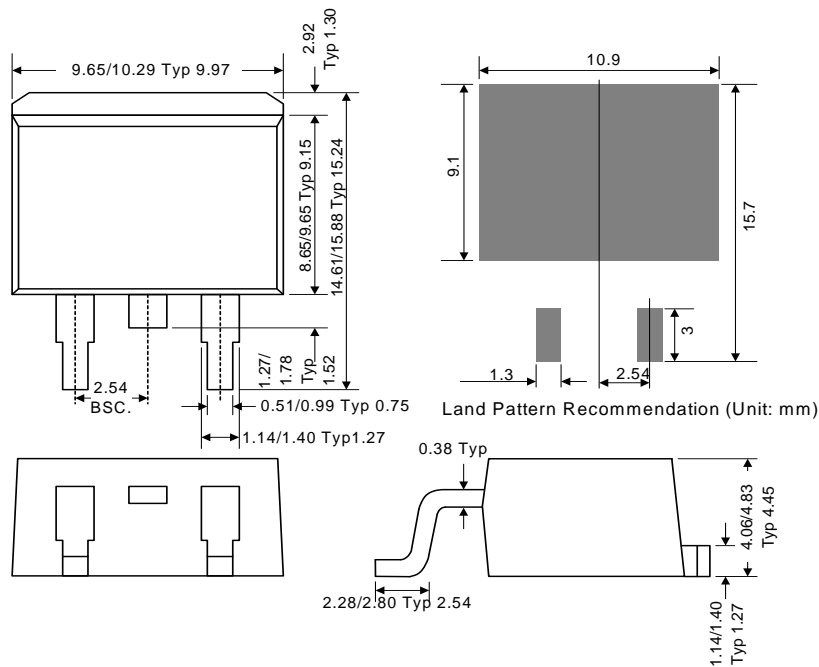

**(5) TO220-3L**

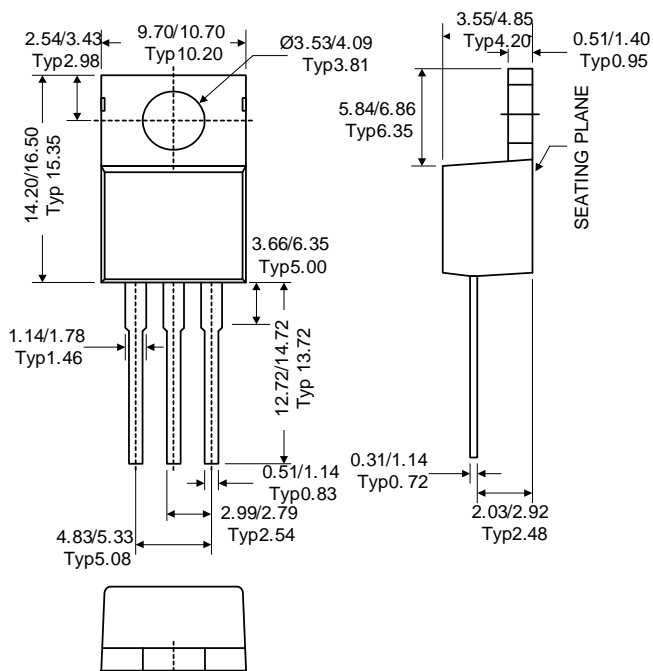

**IMPORTANT NOTICE**

DIODES INCORPORATED MAKES NO WARRANTY OF ANY KIND, EXPRESS OR IMPLIED, WITH REGARDS TO THIS DOCUMENT, INCLUDING, BUT NOT LIMITED TO, THE IMPLIED WARRANTIES OF MERCHANTABILITY AND FITNESS FOR A PARTICULAR PURPOSE (AND THEIR EQUIVALENTS UNDER THE LAWS OF ANY JURISDICTION).

Diodes Incorporated and its subsidiaries reserve the right to make modifications, enhancements, improvements, corrections or other changes without further notice to this document and any product described herein. Diodes Incorporated does not assume any liability arising out of the application or use of this document or any product described herein; neither does Diodes Incorporated convey any license under its patent or trademark rights, nor the rights of others. Any Customer or user of this document or products described herein in such applications shall assume all risks of such use and will agree to hold Diodes Incorporated and all the companies whose products are represented on Diodes Incorporated website, harmless against all damages.

Diodes Incorporated does not warrant or accept any liability whatsoever in respect of any products purchased through unauthorized sales channel.

Should Customers purchase or use Diodes Incorporated products for any unintended or unauthorized application, Customers shall indemnify and hold Diodes Incorporated and its representatives harmless against all claims, damages, expenses, and attorney fees arising out of, directly or indirectly, any claim of personal injury or death associated with such unintended or unauthorized application.

Products described herein may be covered by one or more United States, international or foreign patents pending. Product names and markings noted herein may also be covered by one or more United States, international or foreign trademarks.

**LIFE SUPPORT**

Diodes Incorporated products are specifically not authorized for use as critical components in life support devices or systems without the express written approval of the Chief Executive Officer of Diodes Incorporated. As used herein:

- A. Life support devices or systems are devices or systems which:
1. are intended to implant into the body, or
  2. support or sustain life and whose failure to perform when properly used in accordance with instructions for use provided in the labeling can be reasonably expected to result in significant injury to the user.
- B. A critical component is any component in a life support device or system whose failure to perform can be reasonably expected to cause the failure of the life support device or to affect its safety or effectiveness.

Customers represent that they have all necessary expertise in the safety and regulatory ramifications of their life support devices or systems, and acknowledge and agree that they are solely responsible for all legal, regulatory and safety-related requirements concerning their products and any use of Diodes Incorporated products in such safety-critical, life support devices or systems, notwithstanding any devices- or systems-related information or support that may be provided by Diodes Incorporated. Further, Customers must fully indemnify Diodes Incorporated and its representatives against any damages arising out of the use of Diodes Incorporated products in such safety-critical, life support devices or systems.

Copyright © 2009, Diodes Incorporated

[www.diodes.com](http://www.diodes.com)